

# JALDOOT

## HAND PALLET TRUCK



### STAR FEATURES

- Excellent manoeuvrability
- Hard chrome plated shaft and plunger
- Pallet entry rollers
- Articulation of steering wheels allows smooth running on uneven floor
- Sealed hydraulic unit
- Strong light weight pressed steel chassis
- Maintenance free sealed bearings
- Protection of operator's hand by convenient shape of tiller

## TECHNICAL INFORMATION

Jaldoot Materials Handling Pvt. Ltd., Has been manufacturing rugged and reliable hand pallet trucks for more than 20 years, complying with all market requests. Palmo series of pallet trucks are an indispensable aid to goods movement. They can be used by anyone, with utmost ease.

## TILLER

Conveniently shaped, protecting operator's hand by a strong smooth pipe. The control lever for lifting, lowering and travel movements falls conveniently to hand, making these trucks easy, safe and comfortable to use. The handle returns automatically to vertical position when released. A unique load sensing descent control valve adjusts lowering speed with the load thus permitting jerk free lowering on higher loads.

## FRAME

Robust steel of 5 mm thickness, rounded fork tips protect pallets from being driven into. The entry rollers before and after the load wheels permit easy entry into pallets across bottom deck boards.

## HYDRAULIC LIFTING SYSTEM

Rugged lifting assembly with forged valve block capable of the most demanding use with long life polyurethane seals. The pump cylinder is provided with a heavy duty protective housing, while the lift jack shaft and pump plunger are hard chrome plated. Controlled lowering ensures operating safety and durability.

## WHEELS

Easy going wheels with sealed bearings. Front wheels of cast iron and load wheels of steel ensure long life on normal factory flooring. Forks housing load wheels are of forged steel.

## MAINTENANCE

The hydraulic system and wheel bearing are completely maintenance free. Self lubricating bushing provided on every joints.

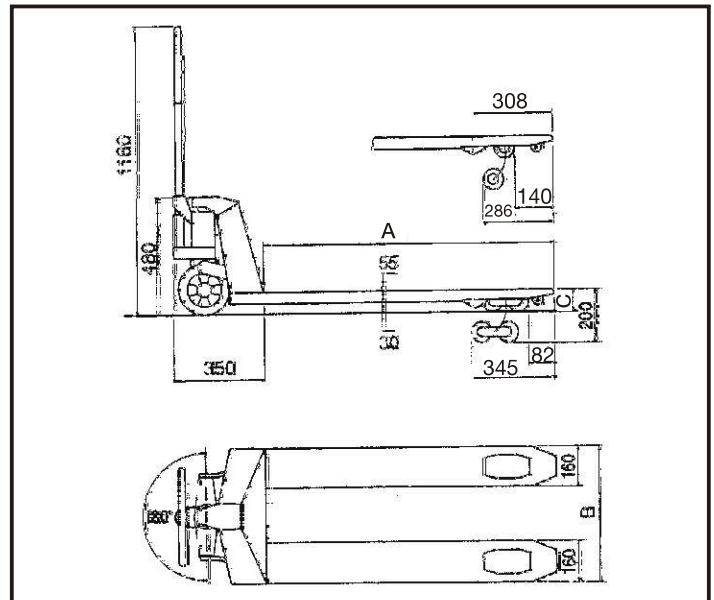

MODEL : PALMO	3015	3020	3025
CAPACITY (in kgs) Uniformly distributed over forks	1500	2000	2500
FORK LENGTH	A MM	915 or 1220	
FORK WIDTH	B MM	560 or 685	
STEERING WHEEL	MM	Ø 200 x 50	
Nylon or Cast Iron			
LOAD WHEEL	MM	Ø 83 x 95 or Ø140 x 95	
Nylon or Cast Steel			
LOWERED HEIGHT	C MM	85 or 140	

## NOTE

- 1) Tandem load wheels provided in model Palmo 3025 as standard fitting.
- 2) Optional:
  - a) Polymer or PU steering wheels
  - b) Polymer or PU load wheels
  - c) Any fork dimensions on request



Single load wheels for easy manoeuvring in closest quarters.

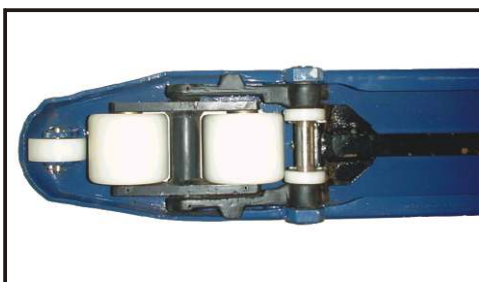

Tandem load wheels for smooth running on uneven surfaces.



# Palmo 3010 SE 1 Tonne Capacity



## OTHER SPECIAL VERSIONS

Palmo 3015-S and 3020-S Flat Bed Truck  
Palmo 3010-SS and 3020-SS Stainless Steel  
Construction for Specialised Applications  
in Chemical / Food Beverages and  
Pharmaceutical Industries.  
Palmo 3020-RT and 3030-RT for  
Convenient Transport of Cylindrical Loads  
( Drums, Paper Rolls Etc. )

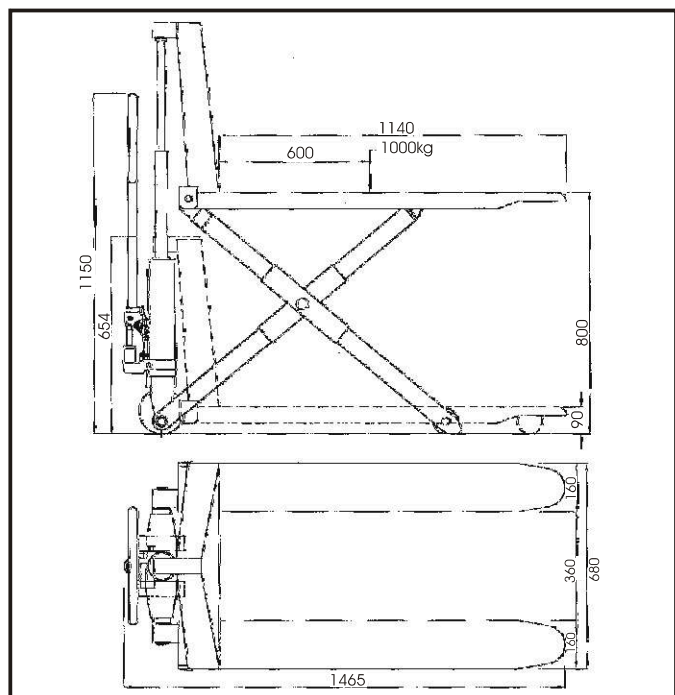

# EQUIPMENTS FOR SPECIAL APPLICATIONS

Battery Operated Pallet Truck



Clamp on Tugger



Scissor Lift Table



Compact Stacker



Counter Balanced Stacker



Heavy Duty Stacker



Drum Handling Stacker



Maintenance Platform Truck



Counter Balanced Fork Lift Truck



Swarf Dumper



Dock Leveller



Manufactured By :

**JALDOOT**  
Materials Handling Pvt. Ltd.

EL-39/2, MIDC, Bhosari, Pune - 411 026

Tel.: 020 - 2712 0412, 2711 1365 Fax : 020 - 2712 1384

Email : [jaldoot@vsnl.com](mailto:jaldoot@vsnl.com) Website : [www.jaldoot.com](http://www.jaldoot.com)